

## MÜLLER MS-U 250 A

Spannvorrichtung / clamping device

TA 1772 US Bl.1(3)

PN: 23112  
Dat.: 23.01.2025  
Name: Wiesemann

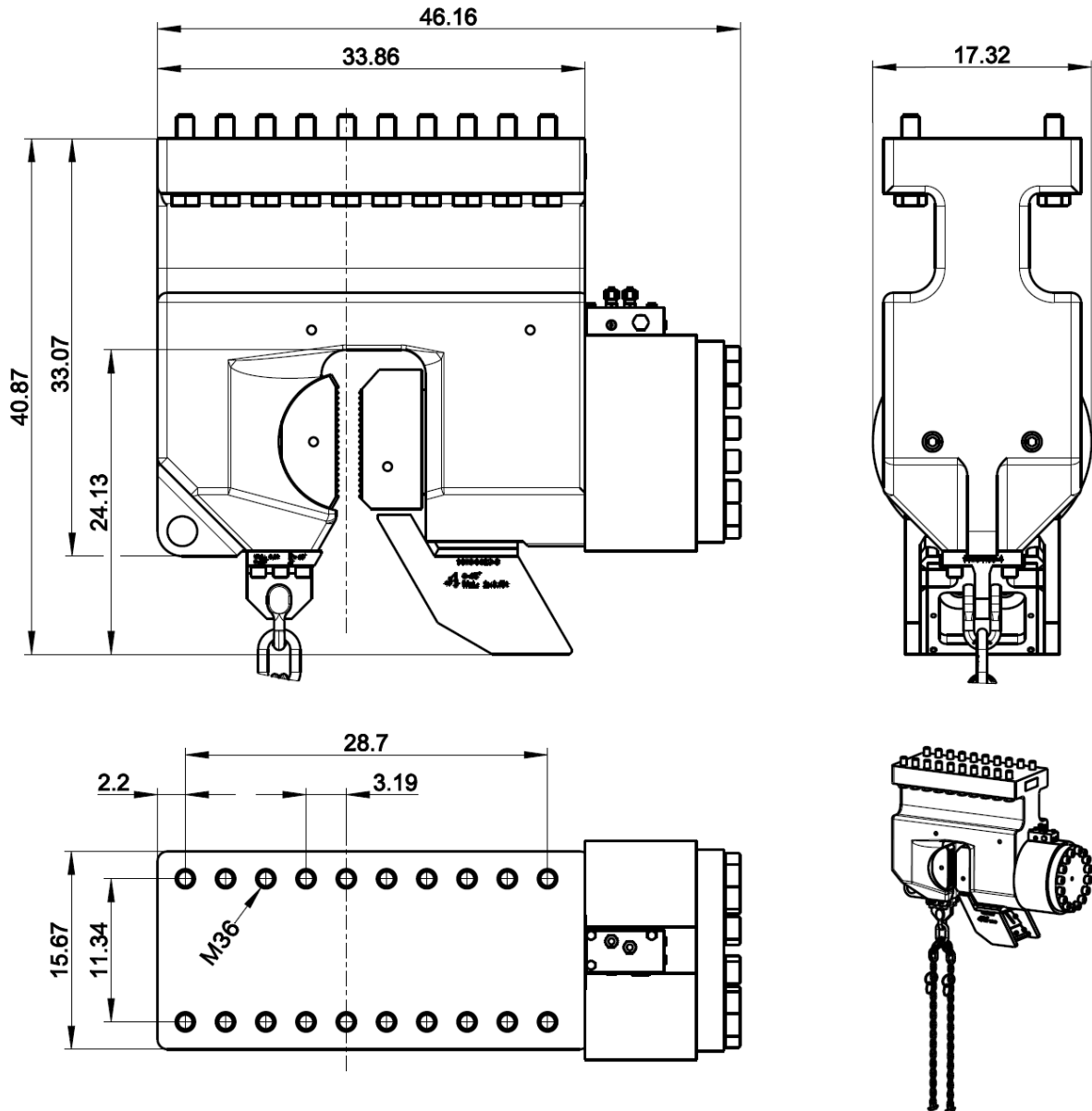

### TECHNISCHE DATEN

Spannkraft, max.  
Spanndruck, max.  
Gewicht

### TECHNICAL DATA

Clamping force, max.  
Clamping pressure, max.  
Weight

281 [US ton]  
5076 [psi]  
4400 [lbs]

Art-Nr. / ID-no.: 50074326

## MÜLLER MS-U 250 A

Spannvorrichtung / clamping device

TA 1772 US Bl.2(3)

PN: 23112  
Dat.: 23.01.2025  
Name: Wiesemann

### Beißbacken / jaw pads

Typ-Z Beißbackenset inkl. Befestigungsmaterial:  
Type-Z jaw pad set incl. fastening material:

**50089824** (Standard)

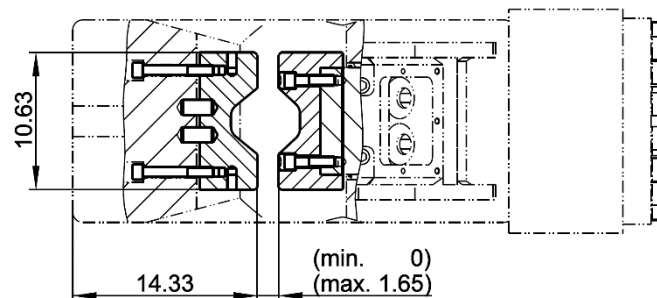

Träger / beams	Doppel Z-Bohle / double Z-pile	Doppel U-Bohle / double U-pile
≥ HEA 400	Alle Z-Profile All Z-Sections	Geometrie im Einzelfall prüfen. Erhöhter Verschleiß durch asymmetrische Auflagefläche. Check geometry in individual cases. Increased wear due to asymmetrical contact surface.
≥ HEB 400		
≥ HEM 450		
≥ IPE 360		
≥ IPN 360		

Typ-U Beißbackenset inkl. Befestigungsmaterial:  
Type-U jaw pad set incl. fastening material:

**50089825** (Option)

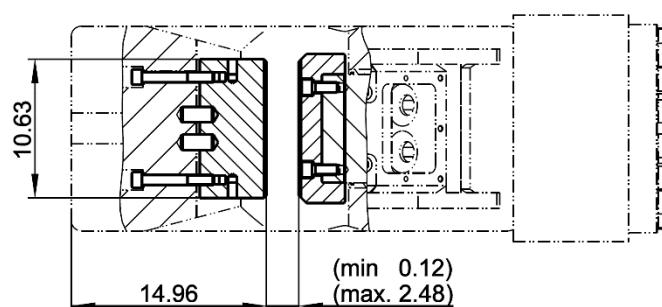

Träger / beams	Einzel Z-Bohle single Z-pile	Einzel U-Bohle single U-pile
≥ HEA 400	Alle Z-Profile All Z-Sections	≥ 19,69in Profilbreite / section width
≥ HEB 400		
≥ HEM 450		
≥ IPE 360		
≥ IPN 360		

## MÜLLER MS-U 250 A

Spannvorrichtung / clamping device

**TA 1772 US** Bl.3(3)

PN: 23112  
Dat.: 23.01.2025  
Name: Wiesemann

### Lastaufhängung / load suspension

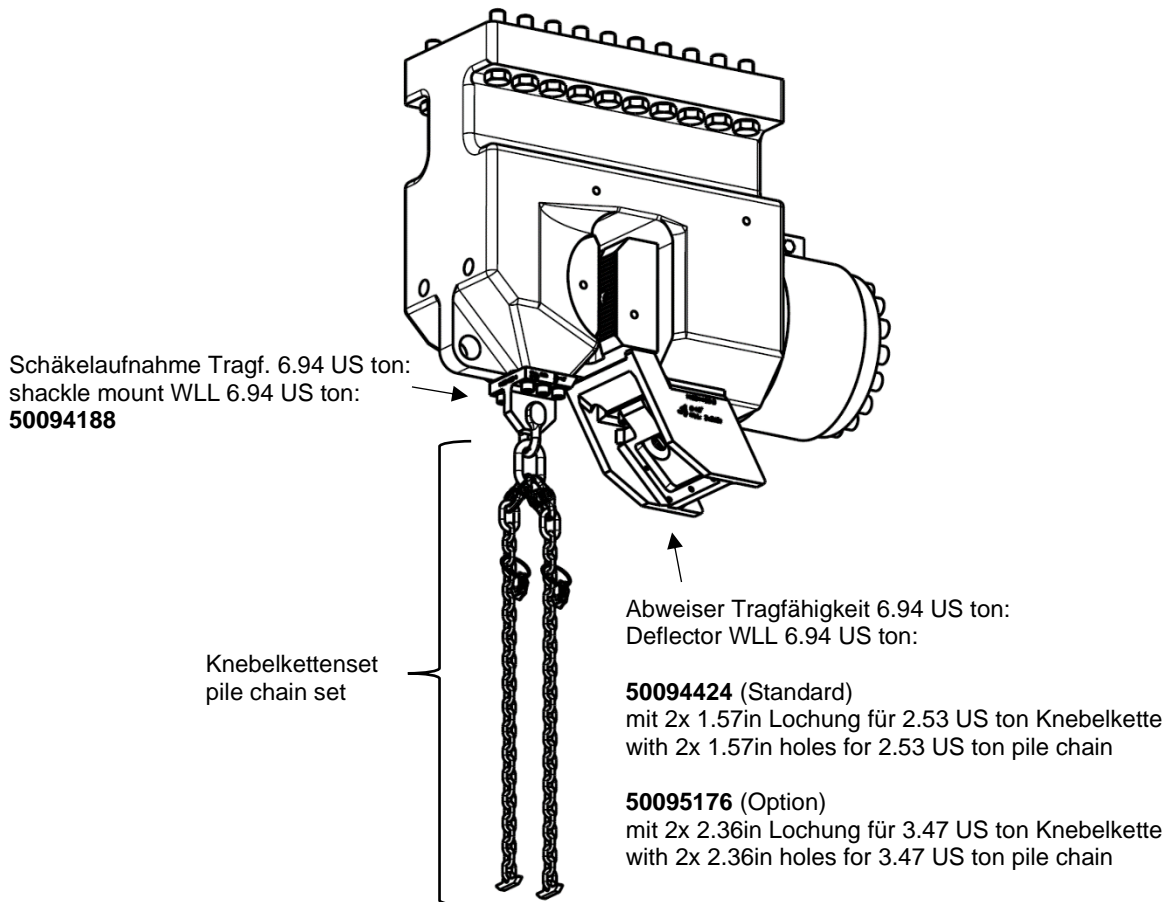

### Zusatzausstattung / additional equipment

Knebelkettenset / pile chain set:

Art. Nr. ID-No.	Knebelkette pile chain		Schäkel shackle 14095005	Zwischenglied intermediate link 14095171	Verbindungsglied connecting link 14094471	
50095065	1x	2.53 US t	1x	-	1x	
50095047		3.47 US t			14086051	14071208
50094470*	2x	2.53 US t		14086051	1x	2x
50095066		3.47 US t		14071208		

\* Standard

Für weitere Knebelketten mit detaillierten Informationen siehe TA1774.  
For more pile chains with detailed information, please find TA1774.