

MÜLLER Vibrationsramme

MS-U 60/72
MS-5 HFBV

TA 1628 us

Dat.: 27.08.2020
Name: Bottenhorn

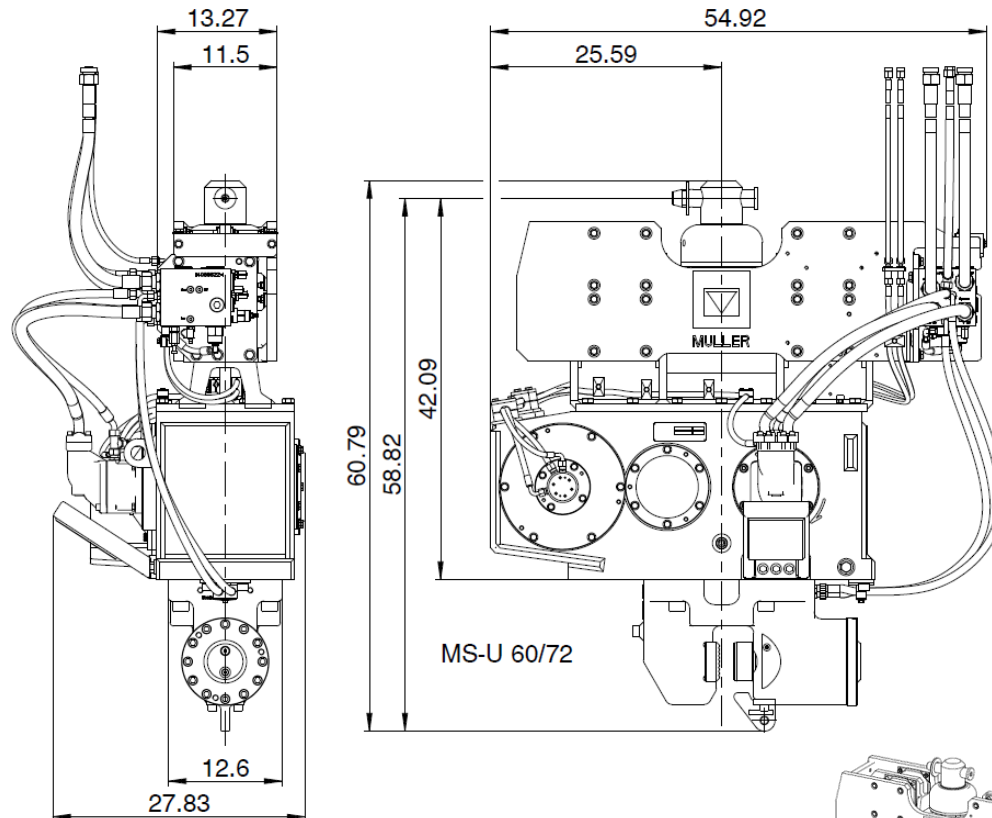

Spannvorrichtung 90° gedreht
clamping device turned 90°

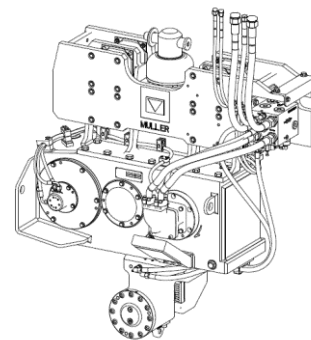

TECHNISCHE DATEN:

TECHNICAL DATA:

gültig ab Ser.-Nr./ valid from serial no.: 8550-4139

Fliehkraft max.	centrifugal force max.	[US ton]	44.95	
Stat. Moment	eccentric moment	[in-lbs]	0-434	
Schwingungsfrequenz max.	oscillation frequency max.	[Hz]	45	
Drehzahl max.	speed max.	[rpm]	2700	
Zugkraft max.	pulling force max.	[US ton]	13.4	
Druckkraft max.	push down max.	[US ton]	9.0	
Gewicht *	weight *	[lbs]	3660	
Gewicht m. Auto-Ampl.*	weight with auto ampl.*	[lbs]	3704	
Gewicht (dynamisch) *	weight (dynamic) *	[lbs]	2579	
Schwingweite max.*	amplitude max.*	[in]	0.33	
				Option
Leistungsaufnahme max.	power max.	[US HP]	127	169
Schluckvolumen max.	volume input max.	[gpm]	42.8	57.1 MS-5 HFBV-5
Schluckvolumen max.	volume input max.	[gpm]	47.5	63.4 MS-5 HFBV-3
Betriebsdruck max.	working pressure max.	[psi]	5076	5076

* mit Spannzange

* with clamping device